

IN-BUILDING ANTENNA SYSTEMS

Our in-building antenna systems are very unique in the industry. All of our antennas are by-products of our customers needs, subway projects, high-rise in-building systems, nuclear power plants, correction facilities, and many more.

Our line of antenna system solutions incorporates single, dual, triple, quad, and 5-band frequency specifications. Our in-house R&D team works with our customers to develop antennas that meet their exact project needs. These antennas are offered in a wide range of radomes, low-profile, 6200 Kydex Fire-Redartant material, ABS High-Impact, aluminum, and custom colors.

We can provide antenna systems, splitters, couplers, taps, cables, connectors, BDAs, and many other necessary components. In our arsenal of antenna products we offer

We offer many different versions and frequencies; the following antenna products are just a sampling. We encourage you and your team to contact us for either technical support or to request a potential new design.

**Please call for a custom antenna design
or to see our other available models.**

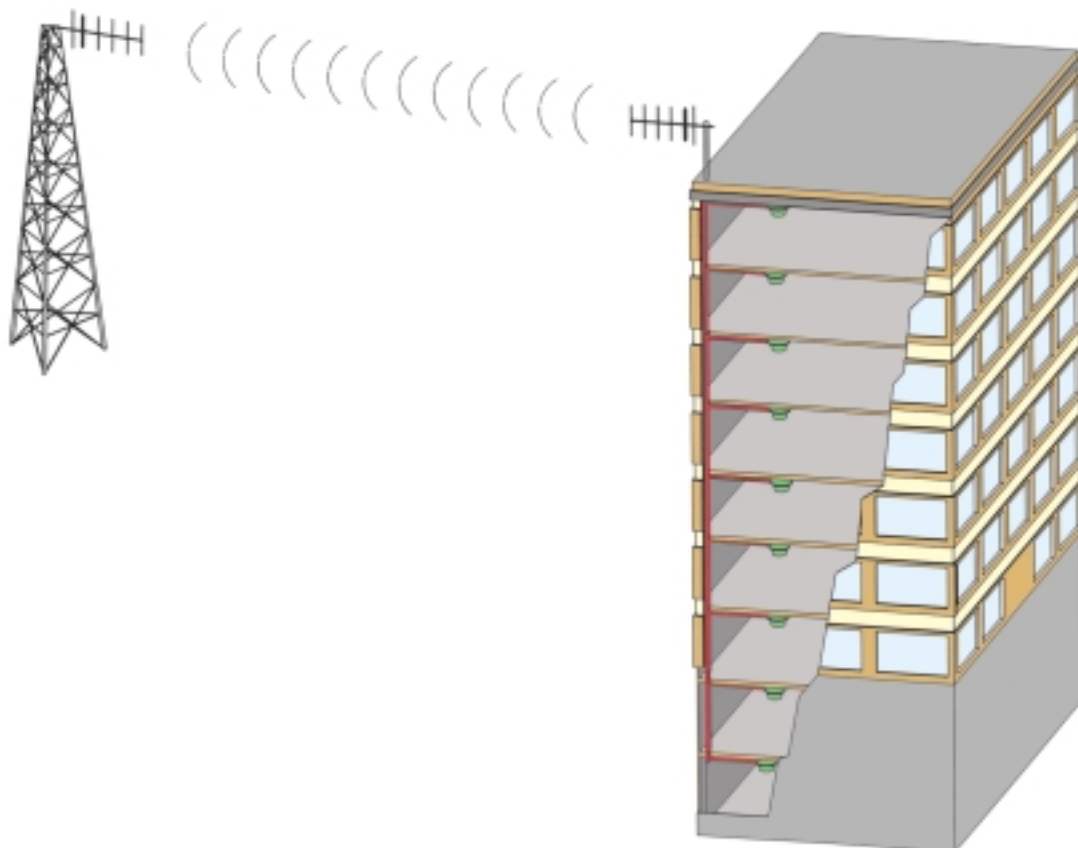

MULTI-BAND ANTENNAS

Multi-Band In-Building Antennas

Our antennas are designed, manufactured and integrated with the most innovative and highly specialized processes, providing our customers with a solid, long-lasting solution for their in-building applications.

Our multi-band antennas are one-of-a-kind and many are the only ones available in the world. They can cover more than three bands in most cases and provide an idea of some of our products.

We offer a wide variety of our antennas with Fire Retardant 6200 Kydex radomes. These radomes are designed for use in in-building applications and public transport vehicles such as underground trains, vans, buses, and trains. They meet the recommended fire safety practices of both the Federal Transit Administration (FTA) and the Federal Rail Administration (FRA) for smoke emission and flammability as tested under ASTM E-662 and ASTM E-162.

Our antennas have been installed all over the world. Some typical installations are Nuclear Power Plants, Correction Centers, Tunnels, High-Rise Buildings, SubWays, Light & Heavy Rail, Power Plants, High-Security Office networks, and Mine Shafts.



F-4005



F-4005

IN-BUILDING

Electrical Specifications	F-3724	F-4005	F-33040	F-33048
Frequency Range, MHz	150 / 450	740-960	806-960 / 1850-1990	740-960
Nominal Gain, dBd	Unity	Unity	Unity	Unity
Bandwidth: 1.5:1 VSWR, MHz				
138-174	4	n/a	n/a	n/a
406-512	20	n/a	n/a	n/a
740-960	n/a	220 - Full Band	n/a	220 - Full Band
806-960	n/a	n/a	72	n/a
1800-1990	n/a	n/a	140	n/a
Polarization	Vertical	Vertical	Vertical	Vertical
Pattern	Omni	Omni	Omni	Omni
Power Rating, Watts	100	50	50	50
Nominal Impedance, Ohms	50	50	50	50
Radome	None - S.S.	6200 Kydex	6200 Kydex	6200 Kydex
Standard Termination	TNC Male (Crimp)	N Female	N Female	3' Jumper - N Female
Mechanical Specifications				
Length, inches (mm)	n/a	2 (51)	2 (51)	2 (51)
Diameter, inches (mm)	n/a	4.5 (114)	4.5 (114)	4.5 (114)
Weight, lbs (kg)	0.375 (0.169)	0.375 (0.169)	0.375 (0.169)	0.375 (0.169)
Min. Ground Plane Size, inches (mm)	n/a	8 x 8 (203 x 203)	8 x 8 (203 x 203)	8 x 8 (203 x 203)
Mounting Information	Adjustable Support	Not Included	Not Included	Not Included

*** Please call for other available models.

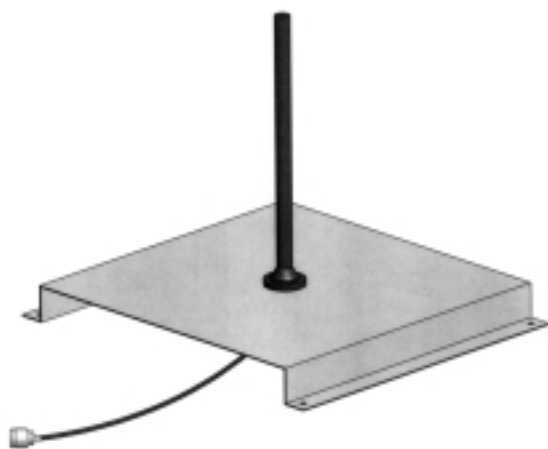

F-3941



F-33048



F-3741NGP

IN-BUILDING

Multi-Band In-Building Antennas

Our antennas are designed, manufactured and integrated with the most innovative and highly specialized processes, providing our customers with a solid, long-lasting solution for their in-building applications.

Our multi-band antennas are one-of-a-kind and many are the only ones available in the world. They can cover more than three bands in most cases and provides an idea of some of our products.

We offer a wide variety of our antennas with Fire Retardant 6200 Kydex radomes. These radomes are designed for use in in-building applications and public transport vehicles such as underground trains, vans, buses, and trains. It meets the recommended fire safety practices of both the Federal Transit Administration (FTA) and the Federal Rail Administration (FRA) for smoke emission and flammability as tested under ASTM E-662 and ASTM E-162.

Our antennas have been installed all over the world. Some typical installations are Nuclear Power Plants, Correction Centers, Tunnels, High-Rise Buildings, SubWays, Light & Heavy Rail, Power Plants, High-Security Office networks, and Mine Shafts.



362-75

IN-BUILDING

Electrical Specifications	357-75	360-75	361-75	362-75
Frequency Range, MHz	136-174	406-512	806-960	806-960
Nominal Gain, dBd	Unity	Unity	Unity	Unity
Bandwidth: 1.5:1 VSWR, MHz	3	20	140	66
Bandwidth: 2.0:1 VSWR, MHz	4	40	140	100
Polarization	Vertical	Vertical	Vertical	Vertical
Pattern	Omni	Omni	Omni	Omni
Power Rating, Watts	150	50	50	100
Nominal Impedance, Ohms	50	50	50	50
Radome	ABS / 6200 Kydex	ABS / 6200 Kydex	ABS / 6200 Kydex	ABS / 6200 Kydex
Color	Grey / White	Grey / White	Grey / White	Grey / White
Standard Termination	UHF / BNC	UHF / BNC	N-Female	N-Female
Mechanical Specifications				
Length, inches (mm)	4.0 (102)	3.0 (76)	3.15 (80)	2.0 (51)
Length, inches (mm)	21.0 (533)	11.0 (279)	9.3 (236)	4.5 (114)
Width, inches (mm)	3.0 (76)	3.25 (83)	n/a	n/a
Weight, lbs (kg)	2.1 (0.945)	1.0 (0.45)	2.5 (1.15)	0.375 (0.169)
Min. Ground Plane Size, inches (mm)	n/a	n/a	14 X 14 (355 X 355)	10 X 10 (254 X 254)

*** Please call for other available models.



360-75

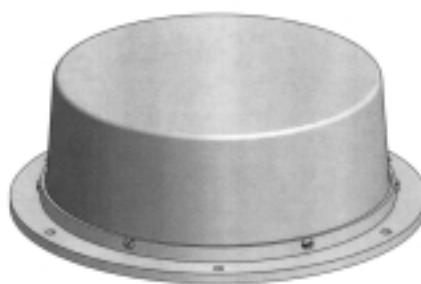

361-75



362-75

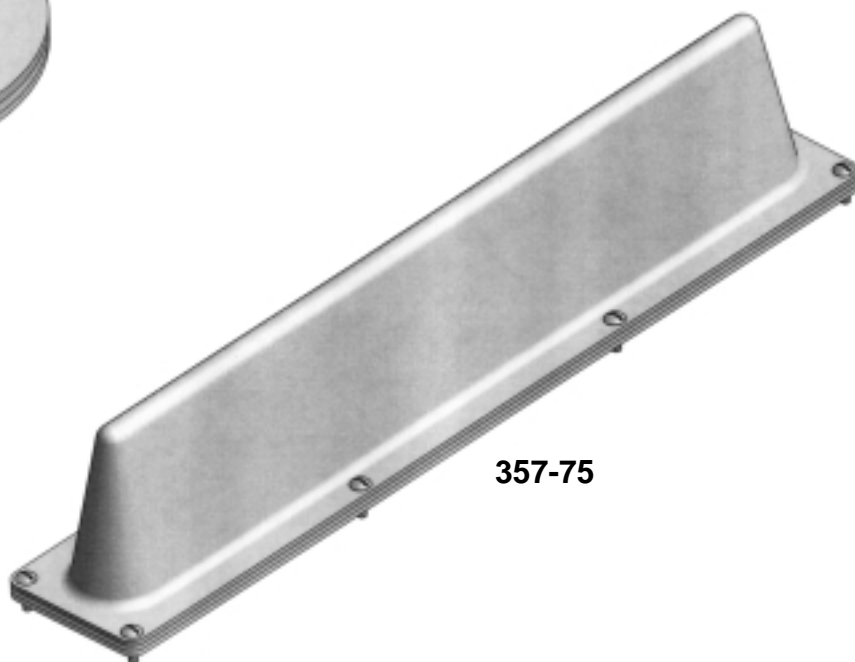

357-75

IN-BUILDING

In-Building Antennas

Our antennas are designed, manufactured and integrated with the most innovative and highly specialized processes, providing our customers with a solid, long-lasting solution for their in-building applications.

Our multi-band antennas are one-of-a-kind and many are the only ones available in the world. They are able to cover more than three bands in most cases and provide an idea of some of our products.

We offer a wide variety of our antennas with Fire Retardant 6200 Kydex radomes. These radomes are designed for use in in-building applications and public transport vehicles such as underground trains, vans, buses, and trains. They meet the recommended fire safety practices of both the Federal Transit Administration (FTA) and the Federal Rail Administration (FRA) for smoke emission and flammability as tested under ASTM E-662 and ASTM E-162.

Our antennas have been installed all over the world. Some typical installations are Nuclear Power Plants, Correction Centers, Tunnels, High-Rise Buildings, SubWays, Light & Heavy Rail, Power Plants, High-Security Office networks, and Mine Shafts.



F-3953

Electrical Specifications	F-3987	F-3953
Frequency Range, MHz	380-470	406-512
Nominal Gain, dBd	Unity	Unity
Bandwidth: 1.5:1 VSWR, MHz	90 @ (2:0:1)	406-470 / 450-512
Polarization	Vertical	Vertical
Pattern	Omni	Omni
Power Rating, Watts	150	50
Nominal Impedance, Ohms	50	50
Radome	Aluminum	Polycarbonate
Color	Black or White	Black or White
Lightning Protection	DC Ground	DC Ground
Standard Termination	NMO	N - Male
Mechanical Specifications		
Length, inches (mm)	6.75 (171)	7.0 (178.5)
Diameter, inches (mm)	0.5 (12.75)	0.625 (15.93)
Weight, lbs (kg)	n/a	n/a
Min. Ground Plane Size, inches (mm)	n/a	8 x 8 (203 x 203)
Mounting Information	Mobile Mount	Included

*** Please call for other available models.

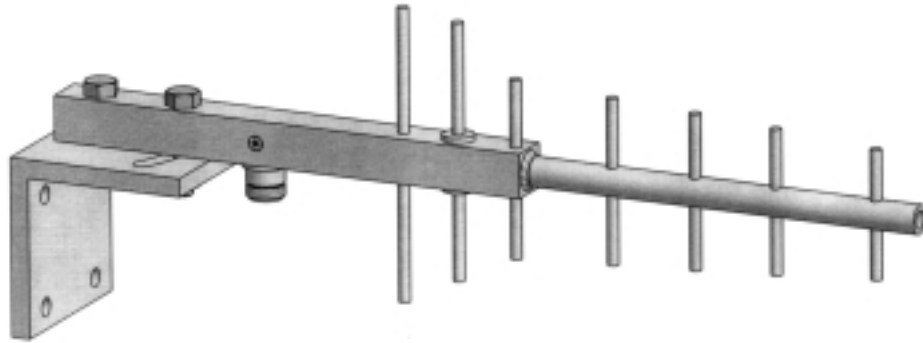

F-3988

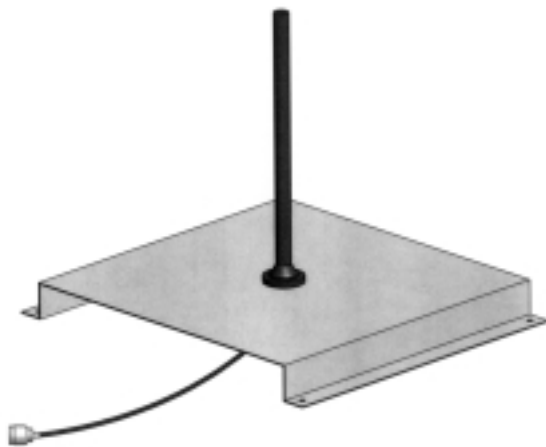

F-3941



F-3953

IN-BUILDING

TRI-BAND ANTENNAS

Multi-Band In-Building Antennas

Our antennas are designed, manufactured and integrated with the most innovative and highly specialized processes, providing our customers with a solid, long-lasting solution for their in-building applications.

Our multi-band antennas are one-of-a-kind and many are the only ones available in the world. They can cover more than three bands in most cases and provide an idea of some of our products.

We offer a wide variety of our antennas with Fire Retardant 6200 Kydex radomes. These radomes are designed for use in in-building applications and public transport vehicles such as underground trains, vans, buses, and trains. They meet the recommended fire safety practices of both the Federal Transit Administration (FTA) and the Federal Rail Administration (FRA) for smoke emission and flammability as tested under ASTM E-662 and ASTM E-162.

Our antennas have been installed all over the world. Some typical installations are Nuclear Power Plants, Correction Centers, Tunnels, High-Rise Buildings, SubWays, Light & Heavy Rail, Power Plants, High-Security Office networks, and Mine Shafts.



F-3749

IN-BUILDING

Electrical Specifications	F-3741*	F-3749*	F-33038
Frequency Range, MHz	VHF / UHF / 806-960	VHF / UHF / 806-960	380-512 / 746-960 / 1800-1990 / 2400-2500
Nominal Gain, dBd	Unity	Unity	Unity
Bandwidth: 1.5:1 VSWR, MHz			
138-174	8	8	n/a
406-512	70	70	n/a
740-960	n/a	n/a	n/a
806-960	154	154	220
1800-1990	n/a	n/a	190
2400-3000	n/a	n/a	600
Polarization	Vertical	Vertical	Vertical
Pattern	Omni	Omni	Omni
Power Rating, Watts	50	50	50
Nominal Impedance, Ohms	50	50	50
Radome	Polycarbonate	6200 Kydex	6200 Kydex
Color	Black	White	White
Lightning Protection	DC Ground	DC Ground	DC Ground
Standard Termination	N-Male	N Female	N Female
Mechanical Specifications			
Length, inches (mm)	11.25 (286.88)	9.78 (249)	n/a
Diameter, inches (mm)	0.65 (16.575)	7.0 (178.5)	n/a
Weight, lbs (kg)	n/a	n/a	n/a
Min. Ground Plane Size, inches (mm)	14 x 14 (357 x 357)	14 x 14 (357 x 357)	none
Mounting Information	Included	Included	none

* 700MHz is also available

*** Please call for more available models.



F-3749



F-3749A

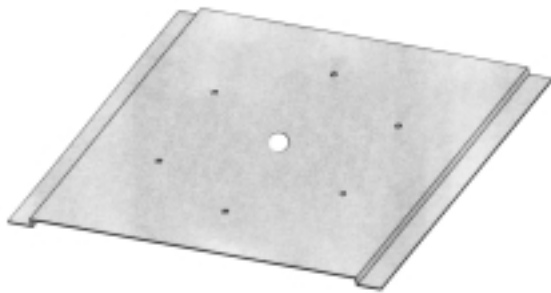

F-3749B2
Optional Mounting Bracket

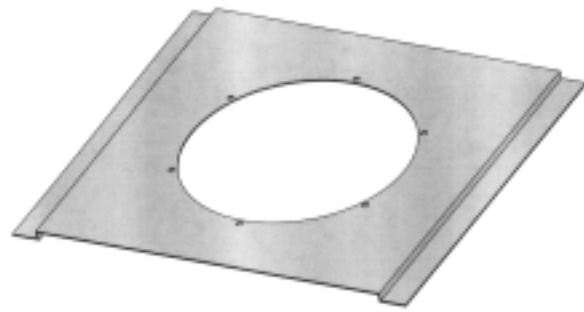

F-3749BR
Optional Mounting Bracket

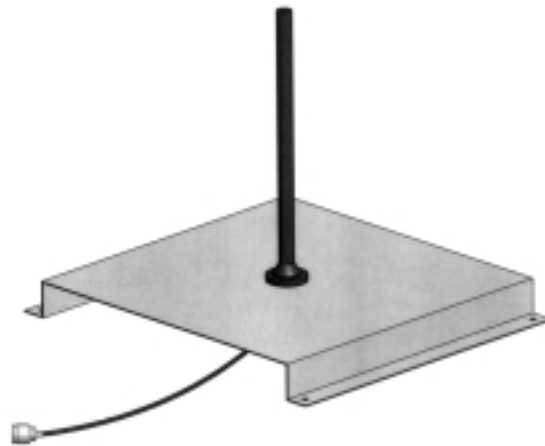

F-3741

CP XBC-FF-PP Series

These Comprod Cross Band Couplers are designed for easy installations, reducing coaxial runs, and for in-building applications with side multi-band antennas. They are available in VHF, UHF, and 800/900 bands. They can be Tower Mounted (TM), Rack Mounted (RM), Tray Mounted (TRM) or stand alone.



Electrical Specifications		XBC-02-80	XBC-02-80R	XBC-38-80	XBC-38-80R	XBC-38-80RX
Frequency Range, MHz	1 st	25-175	25-175	380-512	380-512	380-512
	2 nd	380-960	380-960	806-960	806-960	806-960
Typical Loss, dB	1 st	0.35	0.35	0.20	0.350	0.30
	2 nd	0.50	0.50	0.20	0.50	0.50
Isolation, dB		40	40	40	40	40
Power Rating	1 st	250	Rx Only	250	Rx Only	250
	2 nd	250	Rx Only	250	Rx Only	Rx Only
Connectors		**** N-Female ****				
VSWR		**** 1.25:1 ****				
Temperature		-40°C to +60°C	-40°C to +60°C	-40°C to +60°C	-40°C to +60°C	-40°C to +60°C

Mechanical Specifications	
Dimensions	**** DEPENDS ON MOUNTING CONFIGURATION ****
Rack Mount	**** DEPENDS ON MOUNTING CONFIGURATION ****
Tower Mount	**** DEPENDS ON MOUNTING CONFIGURATION ****

Order Information	19" Rack Mount	Tower Mount	Tray Mount	Without Bracket
XBC-02-80	XBC-02-80-RM	XBC-02-80-TM	XBC-02-80-TRM	XBC-02-80-WB
XBC-02-80R	XBC-02-80R-RM	XBC-02-80R-TM	XBC-02-80R-TRM	XBC-02-80R-WB
XBC-38-80	XBC-38-80-RM	XBC-38-80-TM	XBC-38-80-TRM	XBC-38-80-WB
XBC-38-80R	XBC-38-80R-RM	XBC-38-80R-TM	XBC-38-80R-TRM	XBC-38-80R-WB
XBC-38-80RX	XBC-38-80RX-RM	XBC-38-80RX-TM	XBC-38-80RX-TRM	XBC-38-80RX-WB

FILTERS

CP49-XX-7X Series

Comprod Power Dividers are designed for splitting power in two, three, or four directions. They are available in single, dual, triple or more units.

- **Low Insertion Loss**
- **High Isolation Between Output Ports**
- **Excellent VSWR**

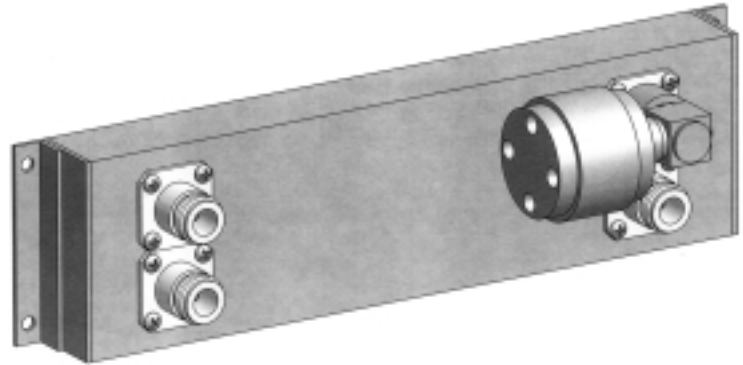

Electrical Specifications	49-14-02	49-40-04	49-40-06	49-40-78	49-80-02	49-80-03
Frequency Range, MHz	144-174	132-174	400-520	400-520	800-1000	800-1000
Power Division	2-Way	4-Way	2-Way	4-Way	2-Way	3-Way
Bandwidth, MHz	30	42	120	120	200	200
Insertion Loss, Max dB	3.2	6.4	3.2	6.4	3.2	5.1
Return Loss	n/a	n/a	n/a	n/a	≤ -20dB	≤ -18dB
Input Power Rating, Watts	800	1000	500	1000	500	1.0
Isolation	n/a	n/a	n/a	n/a	n/a	> 20 dB
Connector	N-Female	N-Female	N-Female	N-Female	N-Female	N Female
Mechanical Specifications						
Maximum Length, (HxLxD) inches	1.8 x 5.25 x 2.5	2.0 x 19 x 2.75	1.8 x 5.25 x 2.5	2.0 x 19 x 2.75	1.8 x 5.25 x 2.5	1.6 x 4.4 x 2.5

** Call for more versions.

Order Information	19" Rack Mount	Without Mount	Standard Mount
49-14-02	49-14-02RM	49-14-02WP	49-14-02
49-13-04	49-13-04RM	49-13-04WP	49-13-04
49-40-02	49-40-02RM	49-40-02WP	49-40-02
49-40-04	49-40-04RM	49-40-04WP	49-40-04
49-80-02	49-80-02RM	49-80-02WP	49-80-02
49-80-03	49-80-03RM	49-80-03WP	49-80-03

